

DIRIS A40 DIRIS A41



diris_561_a_1_x_cat

DIRIS A40

1. Backlit LDC display
2. Direct access key for currents and setup wiring correction
3. Direct access key for voltages and frequency
4. Direct access key for active, reactive, apparent power and power factor
5. Direct access key for max. and average current and power values
6. Direct access key for harmonics values
7. Direct access key for energies and hour run meter.

Functions

The **DIRIS A40** and **A41** are multi-function meter for measuring electrical values in all low and high voltage networks. All the parameters can be configured and displayed on its front panel and measuring and timing functions used.

The user can also connect plug-in modules to the rear of the device at any time, adding such functions as :

- energy metering
- harmonics measurement
- alarms
- communication

Conformity to standards

- IEC 62053-22 class 0,5 S
- IEC 62053-23 class 2
- IEC 61010-1
- IEC 61000-4-2
- IEC 61000-4-3
- IEC 61000-4-4
- IEC 61000-4-5
- IEC 61000-4-6
- IEC 61000-4-8
- IEC 61000-4-11
- IEC 60068-2-6
- IEC 60068-2-11
- IEC 60068-2-30

Applications

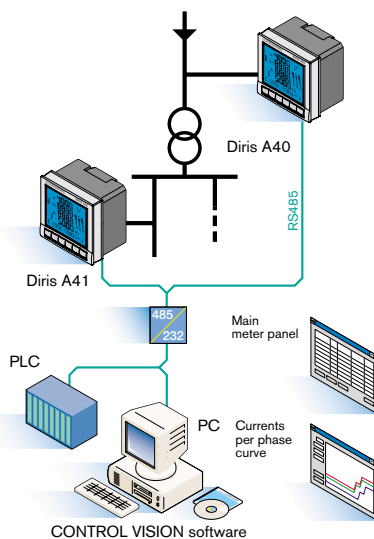

diris_581_a_1_gb_cat

Using electrical parameters mean using several analogue or digital single-function products such as ammeters, voltmeters or wattmeters.

DIRIS A40 and A41, with its six direct access keys and LCD display, helps you use all the parameters in an LV or HV installation. These parameters can be centralized on a PC or PLC through an RS485 link using JBUS/MODBUS® or PROFIBUS® DP protocol. The unit is designed so that the installer can easily fit the DIRIS A40 or A41 to the door of a cabinet. To facilitate and optimize the operator's work, the DIRIS A40 and A41 uses one of the most functional principles for integrating communications, metering, harmonics, analog outputs or alarm relays. Simply fit a module to the rear of the casing to add a function.

Measurement in real effective values (TRMS) of :

- current per phase and instantaneous neutral, average and maximum values over a programmable period
- phase-to-neutral and phase-to-phase voltages

- frequency
- active power on 4 quadrants (\pm) per phase and total in instantaneous, average and maximum values over a programmable period
- reactive power in 4 quadrants (\pm) per phase and total in instant, average and maximum values over a programmable period
- apparent power per phase and total in instantaneous, average and maximum values over a programmable period
- Power Factor (PF) per phase and total with inductive or capacitive indication.
- harmonic distortion rate (thd) up to 49 on the phase to neutral and phase to phase voltages and the currents (thd 3U, thd 3V, thd 3I, thd In).

Meter

- active power meter on 4 quadrants
- reactive power meter on 4 quadrants
- apparent power meter
- Hour run meter to 1/100th of an hour for the duration of operation.



DIRIS A40

DIRIS A41
 Fourth CTs

References

Basic unit

Auxiliary power supply U_s

110 ... 400 VAC / 120 ... 350 VDC
 12 ... 48 VDC

Reference
 4825 **0A40**
 4825 **1A40**

Reference
 4825 **0A41**
 4825 **1A41**

Optional Plug & display modules

Plug-in modules

| Plug-in modules | Reference | Reference |
|---|------------------|------------------|
| Pulse outputs module | 4825 0090 | 4825 0090 |
| Pulse outputs module + harmonics | 4825 0091 | 4825 0091 |
| Communication module RS485 JBUS / MODBUS® | 4825 0092 | 4825 0092 |
| Analogue outputs | 4825 0093 | 4825 0093 |
| Monitoring or control / command | 4825 0094 | 4825 0094 |
| Communication module RS485 PROFIBUS® DP | 4825 0096 | 4825 0096 |

Easy integration of extra functions (maximum 4) by means of modules that the user can snap in at the back of the device at any time.

DIRIS® A40



DIRIS 965 A

DIRIS® A41



DIRIS 964 A

Pulse outputs

2 configurable outputs impulses (type, weight and duration) for \pm kWh, \pm kvarh et \pm kVAh.

Pulse outputs + harmonics

2 configurable outputs impulses (type, weight and duration) for \pm kWh, \pm kvarh et \pm kVAh.
 Harmonics analysis by row up to 15 and by phase for 3I, In, 3V and 3U.

Communication RS485 JBUS / MODBUS®

RS485 link with JBUS/MODBUS® protocol (speed up to 38400 bauds)

Communication PROFIBUS® DP

1 module RS485 and 1 module protocol PROFIBUS® DP (speed up to 1.5 Mbauds)

Analogue outputs

2 configurable outputs on 3I, In, 3V, 3U, F, \pm Σ P, \pm Σ Q, \pm Σ S et Σ PFL/C.
 2 modules may be installed, that 4 analogues outputs max.

2 inputs - 2 outputs

2 inputs for pulse metering or for input status, or 2 outputs for alarm monitoring or output command. The monitoring function allows upper and lower alarm threshold to be programmed with time delay, hysteresis and working method options for the 3I, In, 3U, 3V, \pm Σ P, \pm Σ Q, \pm Σ S, thd I, thd In, thd U.
 Maximum connecting possibility of 3 modules (6 inputs or 6 outputs, but only 2 outputs on alarm.)

DIRIS A40

DIRIS A41

Electrical characteristics

Current measurement on insulated inputs (TRMS)

| | |
|-----------------------------|---------------------------|
| CT primary | 10 000 A |
| CT secondary | 1 and 5 |
| Measurement range | 0 ... 11 kA |
| Input consumption | ≤ 0,1 VA |
| Measurement updating period | 1 s |
| Accuracy | 0,5% |
| Sustained overload | 6 A |
| Intermittent overload | 10 I _n for 1 s |

Voltage measurement (TRMS)

| | |
|--|---------------------------|
| Direct measurement between phases | 50 ... 700 V~ |
| Direct measurement between phase and neutral | 28 ... 404 V~ |
| VT primary | 500 000 V~ |
| VT secondary | 60, 100, 110, 173, 190 V~ |
| Frequency | 50 / 60 Hz |
| Input consumption | ≤ 0,1 VA |
| Measurement updating period | 1 s |
| Accuracy | 0,5% |
| Sustained overload | 760 V~ |

Maximum ratio KI x KV

| | |
|----------------------|------------|
| Limitation for 1A CT | 10 000 000 |
| Limitation for 5A CT | 10 000 000 |

Power measurement

| | |
|-----------------------------|-----|
| Measurement updating period | 1 s |
| Accuracy | 1% |

Power factor measurement

| | |
|-----------------------------|-----|
| Measurement updating period | 1 s |
| Accuracy | 1% |

Frequency measurement

| | |
|-----------------------------|--------------|
| Measurement range | 45 ... 65 Hz |
| Measurement updating period | 1 s |
| Accuracy | 0,1% |

Energy accuracy

| | |
|--------------------------------------|-------------|
| Active (according to IEC 61036) | class 1 |
| Active (according to IEC 62053-22) | class 0,5 S |
| Reactive (according to IEC 62053-23) | class 2 |

Auxiliary power supply

| | |
|--------------|---------------------------------|
| AC voltage | 110 ... 400 V~ |
| AC tolerance | ± 10% |
| DC voltage | 120 ... 350 V = / 24 ... 48 V = |
| DC tolerance | - 6 ... + 20% |
| Frequency | 50 / 60 Hz |
| Consumption | ≤ 10 VA |

Inputs

| | |
|-----------------------------------|-----------------|
| Number | 2 ... 6 |
| Power supply | 10 ... 30 V = |
| Minimum signal width | 10 ms |
| Minimum length between 2 impulses | 18 ms |
| Type | phototransistor |

Outputs (alarms / control)

| | |
|------------------|------------------------|
| Number of relays | 2 |
| Type | 250 V~ - 6 A - 1600 VA |

Outputs (pulse)

| | |
|---------------------------|-------------------------|
| Number of relays | 2 |
| Type | 100 V = - 0,5 A - 10 VA |
| Max. number of operations | ≤ 10 ⁹ |

Outputs (analogue)

| | |
|---------------------|-----------------|
| Number of outputs | 2 ... 4 |
| Type | isolated |
| Range | 0 / 4 ... 20 mA |
| Charging resistance | 600 Ω |
| Maximum current | 30 mA |

Communication

| | |
|--------------------|---------------------------|
| Link | RS485 |
| Type | 2 ... 3 wires half duplex |
| Protocol | JBUS/MODBUS® in RTU mode |
| JBUS/MODBUS® speed | 1400 ... 38400 bauds |
| Protocol | PROFIBUS® DP |
| PROFIBUS® speed | 9,8 kbauds ... 1,5 Mbauds |

Operating conditions

| | |
|-----------------------|------------------|
| Operating temperature | - 10 ... + 55 °C |
| Storage temperature | - 20 ... + 85 °C |
| Relative humidity | 95% |



Overall dimensions

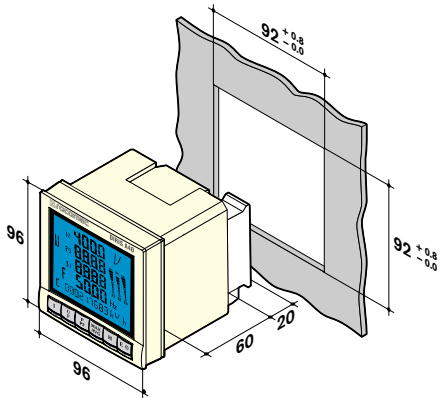

dfile_569_a_1_x_cat

| | |
|--------------------------------------|-----------------------------|
| Type | panel mounting |
| Dimensions H x W x D | 96 x 96 x 60 mm |
| Case protection rating | IP 30 |
| Front protection rating | IP 52 |
| Display type | LCD |
| Terminal block type | fixed or removable |
| Voltage and other connection section | 0,2 ... 2,5 mm ² |
| Current connection section | 0,5 ... 6 mm ² |
| Weight | 400 g |

Terminals

• DIRIS A40

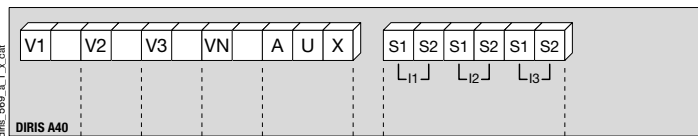

dfile_569_a_1_x_cat

S1 - S2 : current inputs

AUX : auxiliary power supply U_s
 V1, V2, V3 & VN : voltage inputs

• DIRIS A41

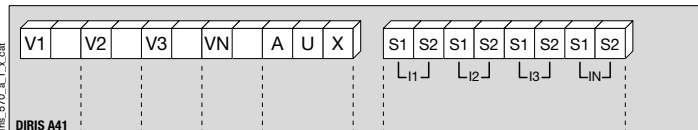

dfile_570_a_1_x_cat

S1 - S2 : current inputs

AUX : auxiliary power supply U_s
 V1, V2, V3 & VN : voltage inputs

• Communication module

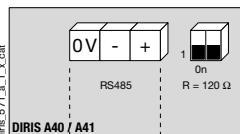

dfile_571_a_1_x_cat

RS485 link
 R = terminaison resistance

• Metering module

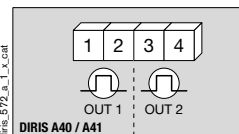

dfile_572_a_1_x_cat

1 - 2 : pulse output no. 1
 3 - 4 : pulse output no. 2

• Analogue outputs module

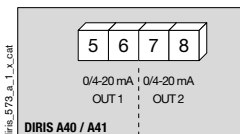

dfile_573_a_1_x_cat

5 - 6 : analogue output n° 1
 7 - 8 : analogue output n° 2

• 2 inputs and 2 outputs

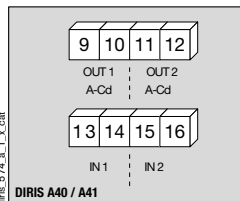

dfile_574_a_1_x_cat

9 - 10 : output relay n°1
 11 - 12 : output relay n°2
 13 - 14 : opto input n°1
 15 - 16 : opto input n°2

DIRIS A40 DIRIS A41

Connections

Recommendation : when disconnecting the DIRIS, it is essential that the secondaries of each current transformer be short-circuited.

This can be done automatically using a product from the SOCOMEC catalogue, the PTI.

▶ Low voltage balanced network for DIRIS A40

• 3/4 wires with 1 CT

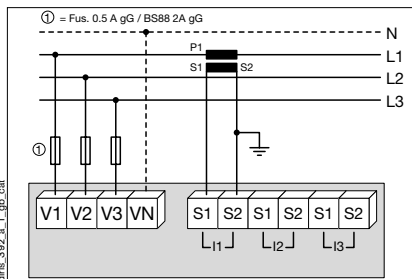

The use of 1 CT reduces by 0.5 % the accuracy of the phases whose current is determined by vector calculation.

• Single phase

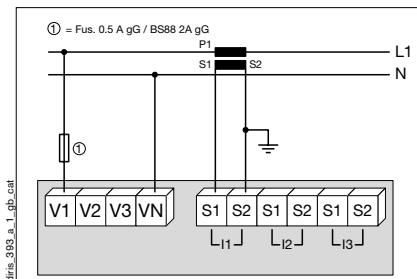

• Two phases

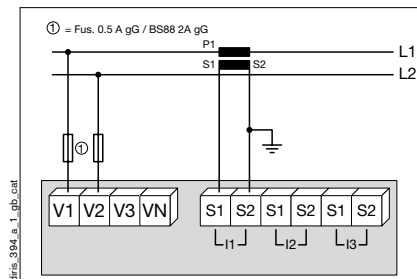

▶ Low voltage unbalanced network for DIRIS A40

• 3/4 wires with 3 CTs

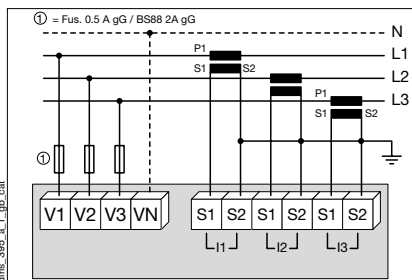

• 3 wires with 2 CTs

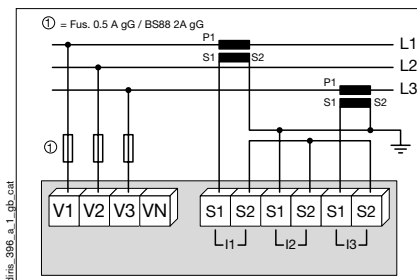

The use of 2 CTs reduces by 0.5 % the accuracy of the phase whose current is worked out by vector calculation.

• 3 wires with 2 CTs

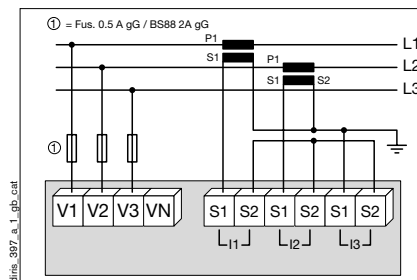

The use of 2 CTs reduces by 0.5 % the accuracy of the phase whose current is worked out by vector calculation.

▶ Low voltage unbalanced network for DIRIS A41

• 4 wires with 4 CTs

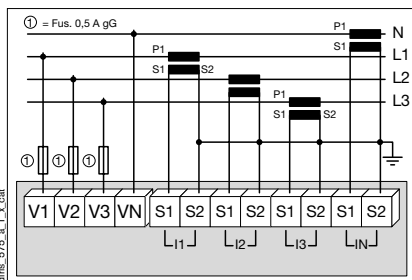

▶ Other information

• Communication via RS485 link

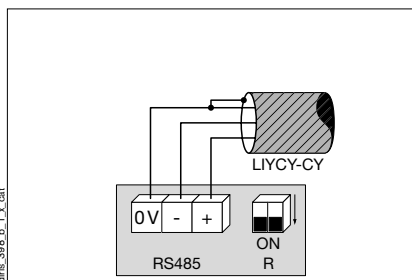

• Connection of voltage transformer for HV networks

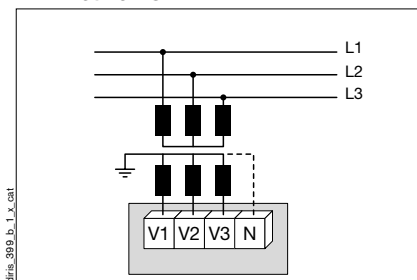

• AC or DC voltage auxiliary power supply

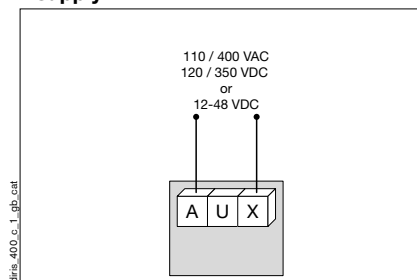

It is recommended that the auxiliary power supply be protected by the use of 500 mA / BS88 2A gG fuses.