



diris_596_b_1_x_cat



Low Voltage Network multi-measurement

➤ Function

The **DIRIS A20** is a multi-function meter for measuring electrical values in all low voltage networks. All the parameters can be configured and displayed on its front panel and measuring and timing functions used.

In addition DIRIS A20 has a function for correcting connection errors.

➤ Conformity to standards

- IEC 62053-22 class 0.5 S
- IEC 62053-23 class 2
- IEC 61010-1
- IEC 61000-4-2
- IEC 61000-4-3
- IEC 61000-4-4
- IEC 61000-4-5
- IEC 61000-4-6
- IEC 61000-4-8
- IEC 61000-4-11
- IEC 60068-2-6
- IEC 60068-2-11
- IEC 60068-2-30
- UL 61010-1
- CSA C22.2 No.61010-1

➤ Applications

Using electrical parameters means using several analog or digital single-function products such as ammeters, voltmeters or wattmeters.

DIRIS A20, with its four direct access keys and LCD display, helps you use all the parameters in an LV installation.

These parameters can be centralized on a PC or PLC through an RS485 link using JBUS/MODBUS protocol®. The casing is designed so that the installer can easily fit the DIRIS A20 to the door of a cabinet. To facilitate and optimize the operator's work, the DIRIS A20 uses one of the most functional principles for integrating communications or metering. Simply fit a module to the rear of the casing to add a function.

Measurement in real effective values (TRMS) of:

- current per phase and neutral in instant,
- phase-to-neutral and phase-to-phase voltages,
- frequency,
- active positive power total in instant and maximum value over a programmable period,
- reactive positive power total in instant,
- apparent positive power total in instant,
- power Factor (PF) total with inductive or capacitive indication,
- harmonic distortion rate (THD) up to 31 on phase-to-neutral and phase-to-phase voltages and currents (THD 3U, THD 3V, THD 3I).

Energies meters

- Positive active energy meter.
- Positive reactive energy meter.

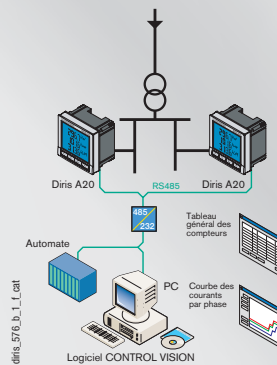

➔ Front panel



1. Backlit LCD display
2. Direct access key for currents (instantaneous and max. values), current THD and set up wiring correction
3. Direct access key for voltages, frequency and voltage THD
4. Direct access key for active, reactive and apparent power (instantaneous and max. values) and power factor
5. Direct access key for energies

➔ Overall dimensions

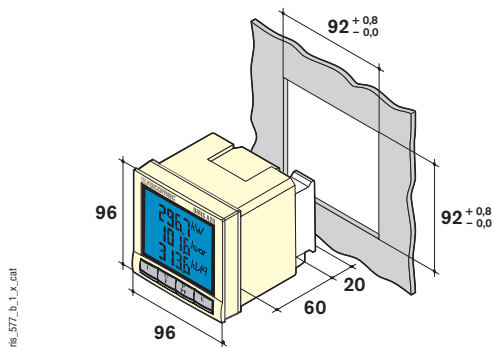

Type	panel mounting
Dimensions W x H x D	96 x 96 x 60 mm
Case protection rating	IP30
Front protection rating	IP52
Display type	LCD
Terminal block type	fixed and pull-out
Voltage and other connection section	0.2 ... 2.5 mm ²
Current connection section	0.5 ... 6 mm ²
Weight	400 g

➔ Plug-in modules

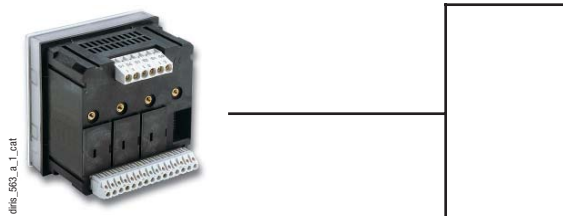

RS485 JBUS / MODBUS® communication

RS485 link with JBUS / MODBUS® protocol and transmission speed up to 38400 bauds.



Pulse outputs

1 configurable pulse output (type, weight and duration).



➔ Accessories

IP65 protection



Device fitted with 144 x 96 mm cut out plate



Characteristics

Current measurement on insulated inputs (TRMS)

CT primary	9 999 A
CT secondary	5 A
Measurement range	0 ... 11 kA
Input consumption	0.6 VA
Measurement updating period	1 s
Accuracy	0.2 %
Sustained overload	6 A
Intermittent overload	10 I _n for 1 s

Voltage measurement (TRMS)

Direct measurement between phases	50 ... 500 VAC
Direct measurement between phase and neutral	28 ... 289 VAC
Input consumption	≤ 0.1 VA
Measurement updating period	1 s
Accuracy	0.2 %
Sustained overload	800 VAC

Power measurement

Measurement updating period	1 s
Accuracy	0.5 %

Power factor measurement

Measurement updating period	1 s
Accuracy	0.5 %

Frequency measurement

Measurement range	45 ... 65 Hz
Measurement updating period	1 s
Accuracy	0.1 %

Energy accuracy

Active (according to IEC 62053-22)	Class 0.5 S
Reactive (according to IEC 62053-23)	Class 2

Auxiliary power supply

AC voltage (IEC)	110 ... 400 VAC
AC voltage (UL/CSA)	110 ... 240 VAC
AC tolerance	± 10 %
DC voltage (IEC)	120 ... 350 VDC
DC voltage (UL/CSA)	120 ... 250 VDC
DC tolerance	± 20 %
Frequency	50 / 60 Hz
Consumption	10 VA

Outputs (pulsed)

Number of relays	1
Type	100 VDC - 0.5 A - 10 VA
Max. number of operations	≤ 10 ⁸

Communication

Link	RS485
Type	2 ... 3 wires half duplex
Protocol	JBUS/MODBUS® in RTU mode
JBUS / MODBUS® speed	1400 ... 38400 bauds

Operating conditions

Operating temperature	- 10 ... + 55 °C
Storage temperature	- 20 ... + 85 °C
Relative humidity	95 %

Terminals

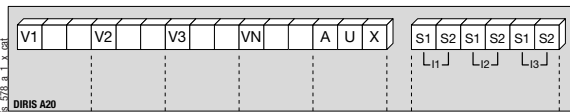

S1 - S2: current inputs

AUX: auxiliary power supply U_s
V1 - V2 - V3 - VN: voltage inputs

Communication module

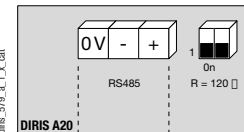

RS485 link
R = 120 Ω: internal resistance for the RS485 link

Metering module

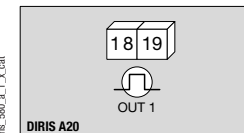

18 - 19: pulse output no. 1

Raccordement

Recommendation

- For IT systems, it is recommended not to connect the CT secondary to earth.
- When disconnecting the DIRIS, the secondaries of each current transformer must be short-circuited. This operation can be carried out automatically with a product in the SOCOMEC catalogue, PTI (only available for 5 A secondary): please consult us.

Low voltage balanced network

3/4 wires with 1 CT

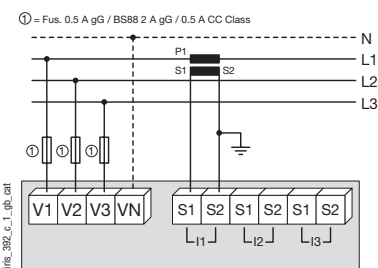

The use of 1 CT reduces by 0.5 % the accuracy of the phases whose current is determined by vector calculation.

Single phase

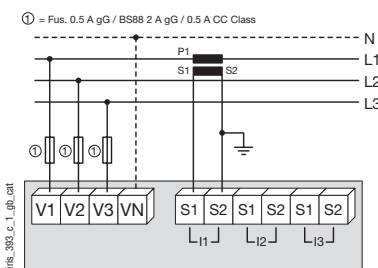

Two phases

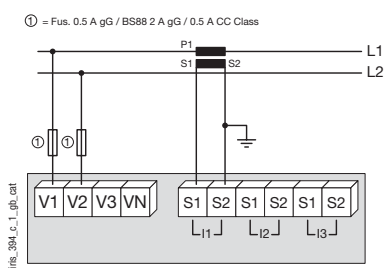

Low voltage unbalanced network

3/4 wires with 3 CTs

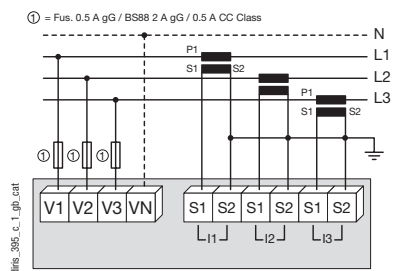

3 wires with 2 CTs

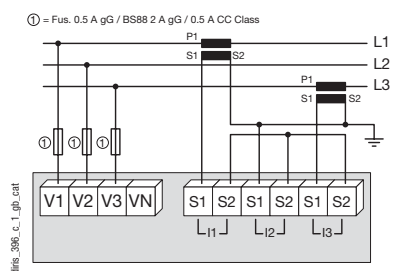

The use of 2 CTs reduces by 0.5 % the accuracy of the phase whose current is determined by vector calculation.

3 wires with 2 CTs

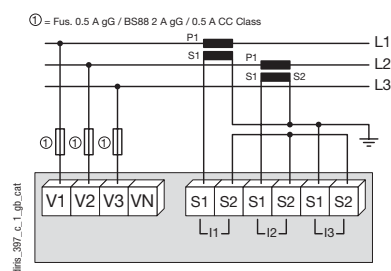

The use of 2 CTs reduces by 0.5 % the accuracy of the phase whose current is determined by vector calculation.

Other informations

Communication via RS485 link

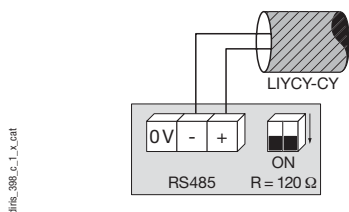

AC & DC auxiliary power supply

120 / 350 VDC (IEC)
110 / 240 VAC (UL/CSA)
120 / 250 VDC (UL/CSA)

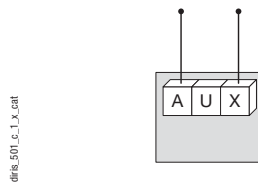

It is recommended that the auxiliary power supply be protected by the use of 500 mA gG, BS88 2A gG or 500 mA CC Class fuses.

References

Base unit



DIRIS A20
Reference
4825 0A20

Auxiliary power supply U_s

110 ... 400 VAC / 120 ... 350 VDC

Options plug-in modules

Reference

Pulse outputs
RS485 JBUS / MODBUS® communication

4825 0080
4825 0082

Accessories

Reference

IP65 protection cover (not UL/CSA)
Fitting kit for 144 x 96 mm cut out (not UL/CSA)

4825 0089
4825 0088